

BRD8034/D  
Rev. 0, Jun-2004

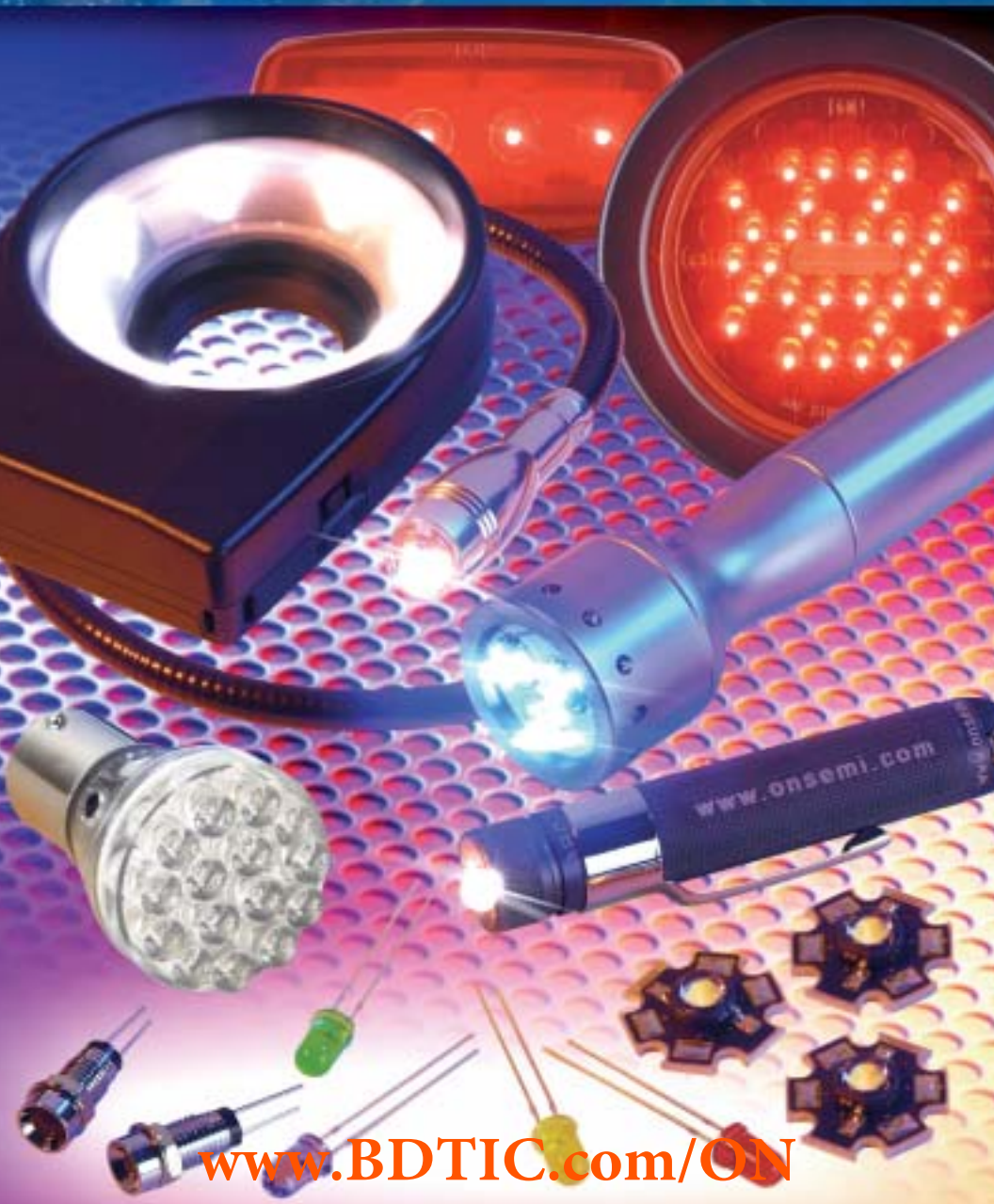

# LED Circuit Solutions



[www.BDTIC.com/ON](http://www.BDTIC.com/ON)

# ON Semiconductor LED Circuit Solutions

---

The advent of high-intensity LEDs with color is changing the world of illumination!

New high-brightness LEDs are appearing rapidly with brilliant colors (red, green, blue and white) and extremely high light output.

The benefits of electronic lighting include low power dissipation compared to conventional alternatives, greater robustness and highly flexible mounting options. Add to this the purity of the available light and the wide breadth of control available in both intensity and color-mixing, and you have another electronic revolution in the making.

The key to maximizing the opportunity available with high-brightness LED lighting is in the



control of the device. This is where ON Semiconductor shines the brightest!

ON Semiconductor has made available more than 20 application solutions for controlling the most popular high-brightness LEDs as illustrated in the following applications section of this brochure. For an even greater offering of application solutions, please visit our website at [www.onsemi.com/leds](http://www.onsemi.com/leds).

Welcome to the beautifully bright world of LED lighting with ON Semiconductor!

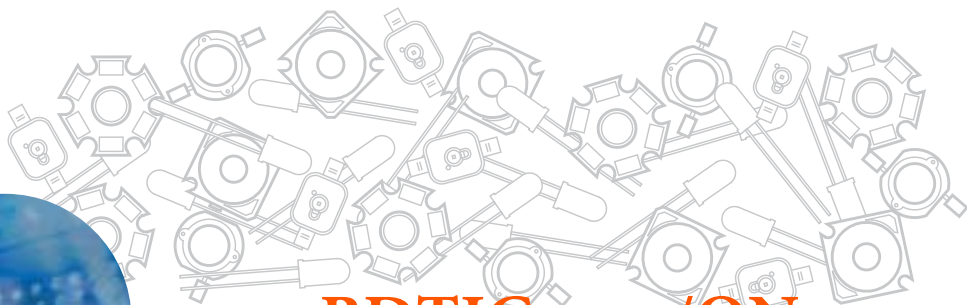

# Device Offerings and Applications

ON Semiconductor Integrated Circuits	Application	ON Semiconductor Support Devices	Page	Demo Bd*
<b>AC – Mains Offline Applications</b>				
LM317	Low-Cost Capacitor-Drop LED Driver (Half-Wave)	1N4004, 1N4749	4	✓
LM317	Low-Cost Capacitor-Drop LED Driver (Full-Wave)	1N4004, 1N5359A	4	✓
NCP1014	Universal AC Input Range, 3-LED Driver (350 mA)	1N4006, MUR160, MUR120, 1N5338B, 1N5917, MSD914	4	✓
NCP1200A	AC Input 1 A LED Driver	1N4004, MUR240, MTD6N20E	5	-
<b>AC – Low Voltage Applications</b>				
CS51411 + NCS2001	12 VAC Input Single LED Controller (Buck)	1N4001, MMSZ4689T1, 1N5818, MMSD914T1	7	-
MC33269	12 VAC Input Constant Current LED Controller	None Required	6	-
NUD4001	12 VAC Input Landscape Lighting LED Controller	MURA105T3	6	✓
<b>DC – Portable/Battery Applications</b>				
CS51411 + NCS2001	Buck Converter for Flashlight	1N4148, 1N5817	13	-
CS5171 + NCS2001	SEPIC Converter for LED Drive	MBRM110LT1	10	-
MC34063 + NCS2001	Buck Converter for Flashlight	MBRM110LT1	14	✓
NCP1403	Buck Converter for Flashlight with Current Limit	MGSF1P02LT1, MBRM110LT1	13	-
NCP1421	White LED Flash/Torch w/ Low Off Current Drain	None Required	13	✓
NCP1421 + NCS2001 + NL17SZ14 + NL7WB66 + NL17SZ02 + NL17SZ74 (2)	Flashlight with Off/Low/High Control	None Required	11	-
NCP1450 + NCS2001	Boost Converter for >1000 mA LEDs	MBRS320, NTGS3446T1 (or MMJT9410)	10	-
NCP5007	Boost Converter to Drive 5 White LEDs in Parallel	MBR0530	12	✓
NCP5008	Backlight LED Boost Driver	MBR0520	12	✓
<b>DC – Automotive &amp; 12-24 VDC Applications</b>				
NCP1442 + LM2902N	12 VDC Input Controller for 1 Amp LED (SEPIC)	MBRS230T3, 1SMA5934BT3	8	-
NCV33063	Automotive Stop Lamp/Tail Lamp LED Driver	MRA4003T3, 1SMB40AT3, NTD2955, MMSZ20T1, MBR140SFT1	9	-
NCV33163	12 VDC Input Controller for 7-to-10 LEDs (350 mA)	MMSZ5260, MMSZ43 or 1N5260	8	-
NUD4001	Automotive Dome Light 200 mA LED Controller	MRA4004	9	-

\* Demo boards. ✓ indicates that there are demo boards stocked and available. Additional demo boards, indicated with a "-", may be created for specific applications upon request. Please contact your local ON Semiconductor Sales Representative.



# AC Mains Offline Applications

## Half/Full Wave Capacitor Drop Circuit

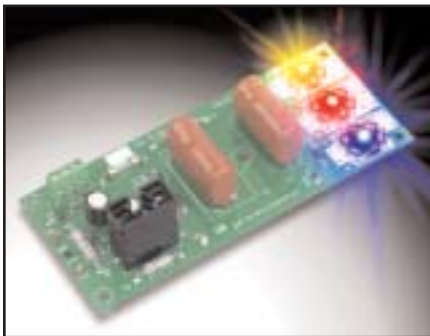
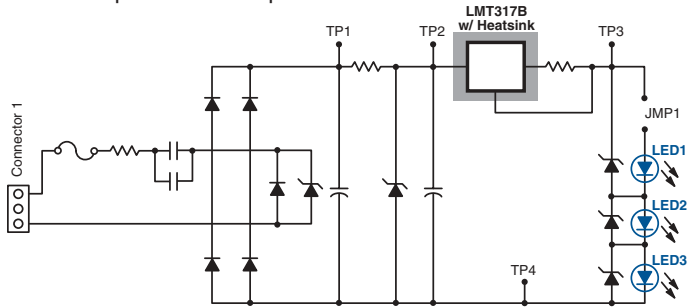

## Typical Applications

- Track Lighting
- Indoor Lighting
- Indoor Highlight Lighting for Artwork
- Low Cost
- Can Drive 0-3 Watts

## NCP1014-Based Offline LED Driver

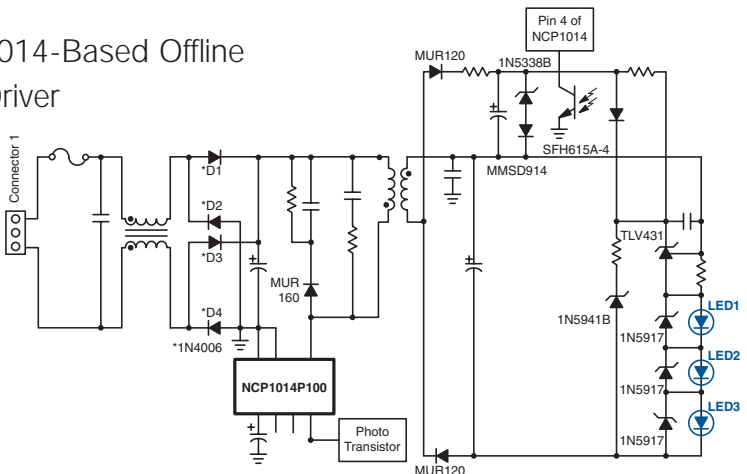

## NCP1200A Offline Buck 1 Amp LED Driver

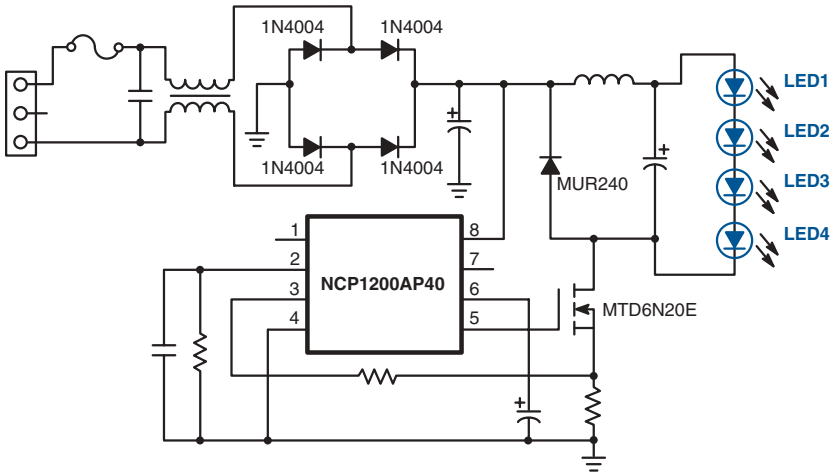

### Typical Applications

- Signage
- Outdoor, High-Power Lighting
- Indoor & Outdoor Architectural Lighting
- Flexibility
- Up to 1-35 Watt
- Up to 1 Amp

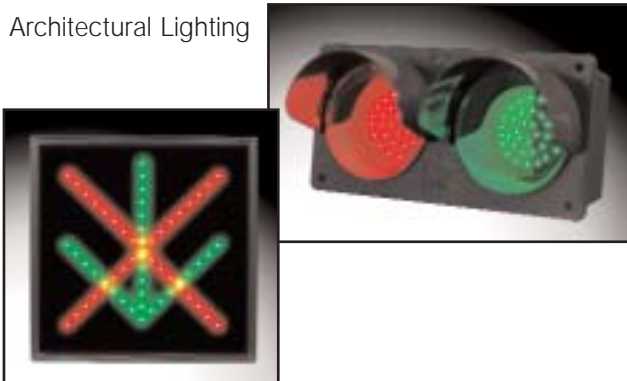

# Low Voltage (12 V) AC/DC Applications

## Simple Constant Current 12 VAC Input System

### Typical Applications

- Outdoor 12 VAC Lighting
- Low Cost

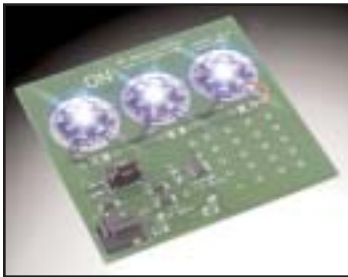
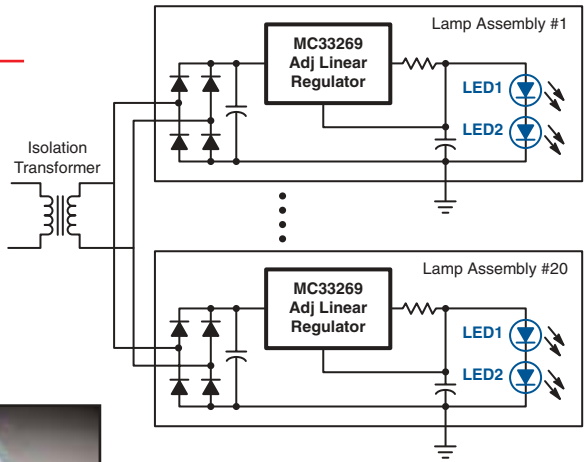

## NUD4001 - Low Voltage AC LED Driver

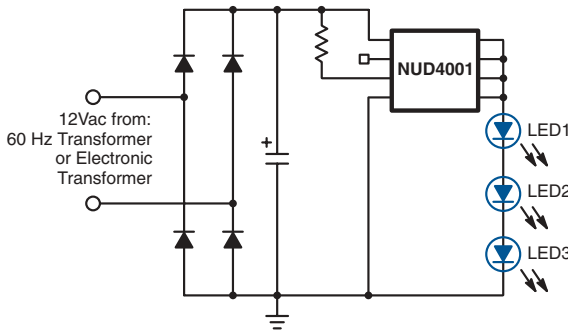

### Typical Applications

- Low-Level Landscape Lighting
- Low Cost

## 12 VAC Input Single LED Driver with Amplifier (Buck)

### Typical Applications

- Interior Automotive Applications
  - Dome Lights
  - Map Lights
  - Dashboard Lights
- Landscape Lighting
- Pool Lighting
- Outdoor Lighting

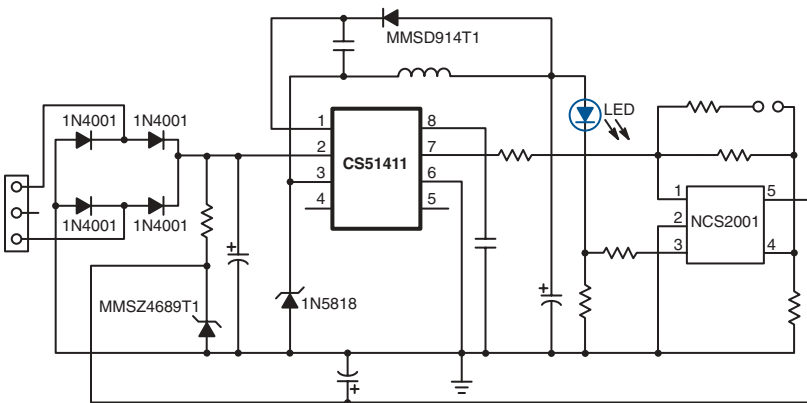

# Low Voltage (12 V) AC/DC Applications

## 12 VDC Input Controller for 1 Amp LED (SEPIC)

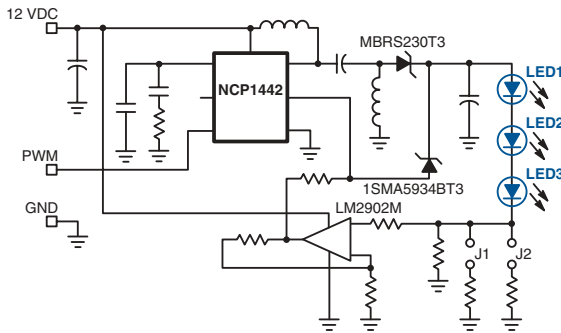

### Typical Applications

- Med to High Intensity Lighting
- Railroad Headlights
- Interior Truck Lighting
- 3-18 Watts

## 12 VDC Input Controller for 7-to-10 LEDs (350 mA)

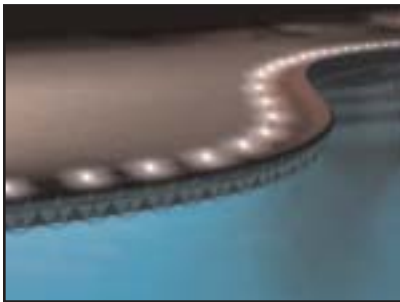

### Typical Applications

- Garden Path Lighting
- Rope Lights
- Pool Lighting

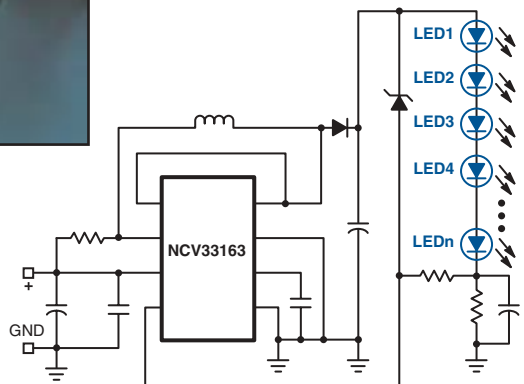



## 12 VDC Automotive Stop Lamp/Tail Lamp LED Driver

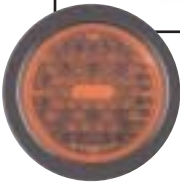
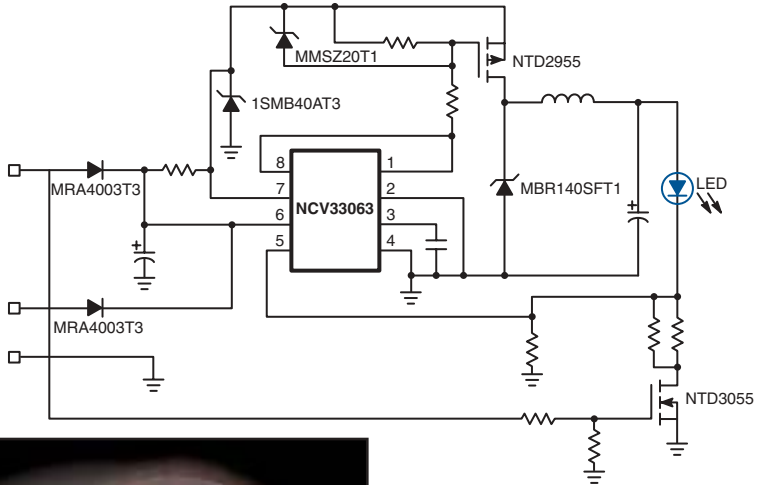

## 12 VDC Automotive Dome Light 200 mA LED Controller

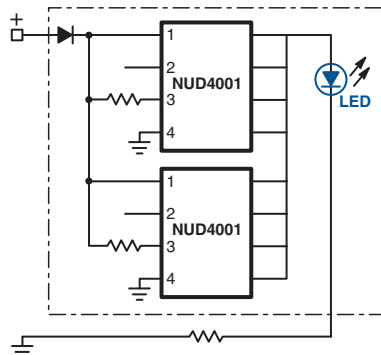

# Portable/Battery Applications

## SEPIC Converter for LED Drive



### Typical Applications

- Miners' Helmet Lighting
- Extremely Long Life Capacity from DC Source

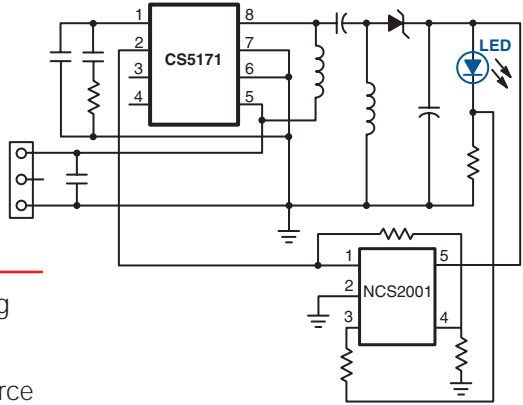

## Boost Converter for >1000 mA LEDs

### Typical Applications

- Flashlights
- Portable Lights

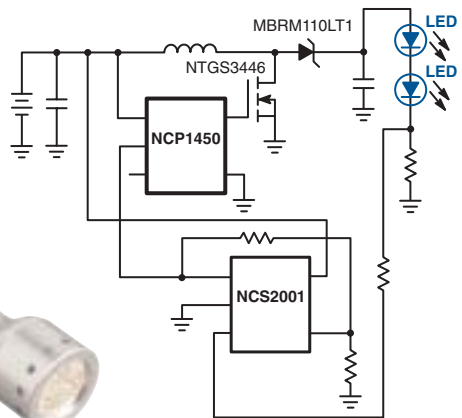

## Flashlight with Off/Low/High Control

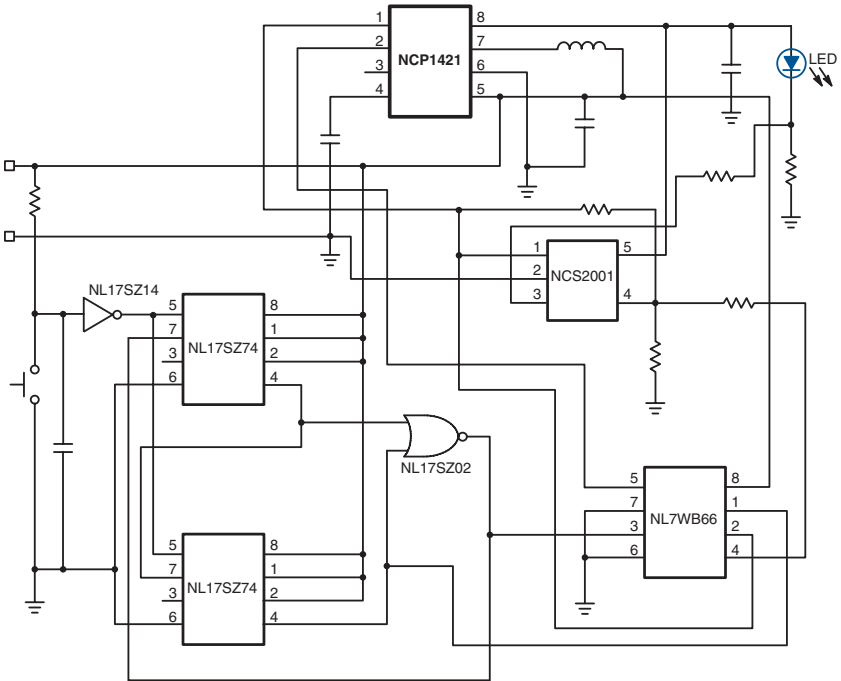

## Portable/Battery Applications (cont.)

Boost Converter to Drive 5 White LEDs in Parallel

### Typical Applications

- Backlighting for
  - ♦ Cellular Phones
  - ♦ PDAs
  - ♦ MP3 Players

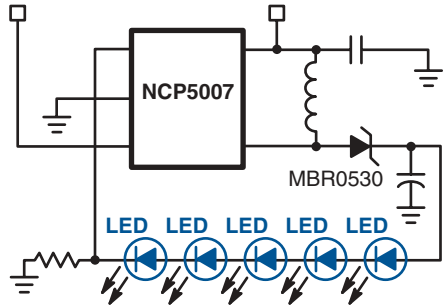

Backlight LED Boost Driver with Photo Sense

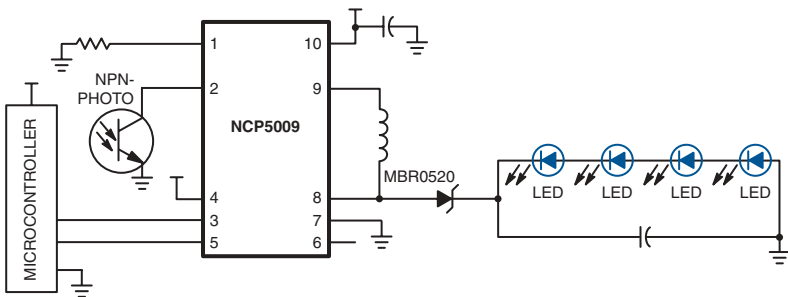

## Buck Converter Flashlight with Current Sense

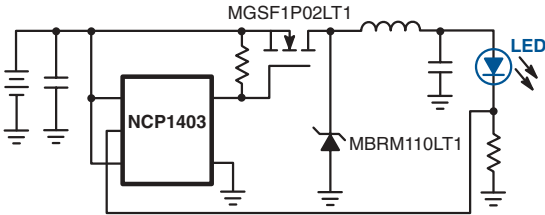

## White LED Flash/Torch with Low Off Current Drain

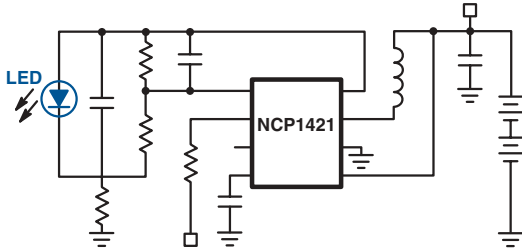

## Buck Converter for Flashlight

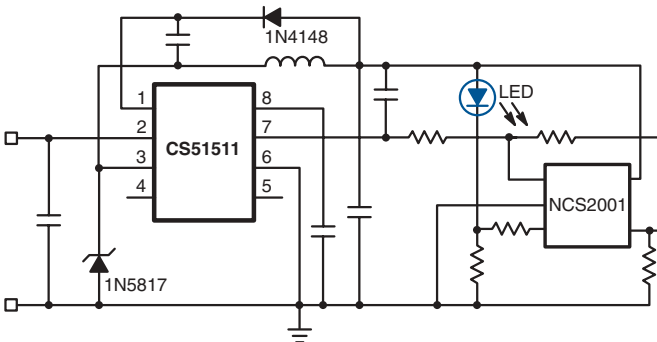

## Portable/Battery Applications (cont.)

### Buck Converter for Flashlight

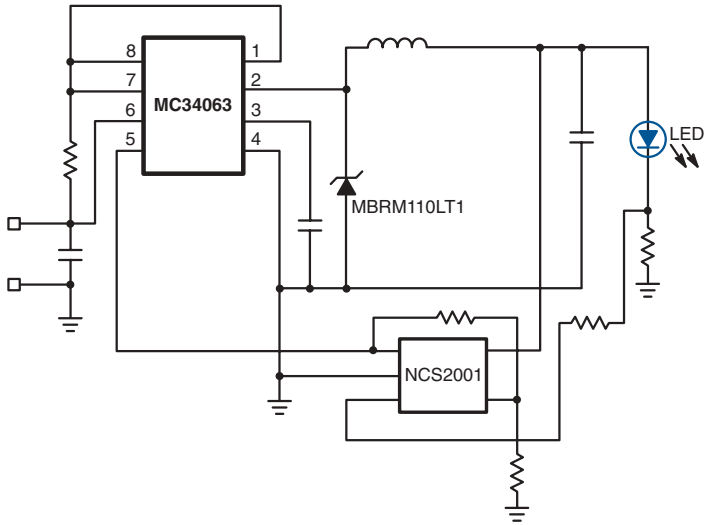

MC34063 Buck Demo Board from ON Semiconductor

## Additional Applications

For more information on the applications and designs in this brochure, along with detailed information on the applications and devices listed below, please visit our website at [www.onsemi.com/leds](http://www.onsemi.com/leds).

ON Semiconductor Integrated Circuits	Application	ON Semiconductor Support Devices	Demo Bd*
<b>AC – Mains Offline Applications</b>			
NCP1200A	Wide Range AC Input Multiple LED Driver	NTD4N60	-
<b>AC – Low Voltage Applications</b>			
CS51411	12 VAC Input Single LED Controller (Buck)	1N4001, 1N58518, MMSD914T1	-
MC34063	12 VAC or DC Input Boost Controller for 5-to-8 LEDs	1N4004, 1SMB5939BT3, 1N5819, 1SMB5918BT3	✓
MC34063	12 VAC Input Controller for 3 LEDs (Buck)	1N5817	✓
<b>DC – Portable/Battery Applications</b>			
MC34063	Buck Converter for Flashlight with Current Limit	MBRM110LT1	-
NCP1400A	One Cell Boost Current Source 50 mA	MBRM110LT1	-
NCP1421	White LED Flashlight Boost Controller (500 mA)	None Required	✓
NCP1422 + NCS2001 + NCP301LSN49T1	Boost Converter for 3 LEDs with Voltage Detect	MBRS320T3, MMSD914T1 (2)	-
NCP1404	Boost Converter with Low Battery Detector	MBRM110LT1	✓
NLSF595	Tri-Color LED Driver	None Required	✓
<b>DC – Automotive &amp; 12-24 VDC Applications</b>			
CS51411 + NCS2001	12-20 VDC Input Single LED Controller (Buck)	MBR120ESFT1, 1N4148, 1N5817, 1SMB5917BT3	-
MC33269	12 VDC Constant Current Controller for 2 LEDs	None Required	-
MC33269	Multiple LEDs with Parallel Constant Current Supply	MBR140, SA20A	-
UC3843A	8-to-20 VDC Input 3-to-10 LED Driver (SEPIC)	NTP18N06L, 2N3904, MBR360, 1N5941B, 1N5918B	-

\*Demo boards. ✓ indicates that there are demo boards stocked and available. Additional demo boards, indicated with a "-", may be created for specific applications upon request. Please contact your local ON Semiconductor Sales Representative.





[www.onsemi.com](http://www.onsemi.com)

© 2004, Semiconductor Components Industries, LLC.

ON Semiconductor and the ON logo are registered trademarks of Semiconductor Components Industries, LLC (SCILLC). SCILLC reserves the right to make changes without further notice to any products herein. SCILLC makes no warranty, representation or guarantee regarding the suitability of its products for any particular purpose, nor does SCILLC assume any liability arising out of the application or use of any product or circuit, and specifically disclaims any and all liability, including without limitation special, consequential or incidental damages. "Typical" parameters which may be provided in SCILLC data sheets and/or specifications can and do vary in different applications and actual performance may vary over time. All operating parameters, including "typicals" must be validated for each customer application by customer's technical experts. SCILLC does not convey any license under its patent rights nor the rights of others. SCILLC products are not designed, intended, or authorized for use as components in systems intended for surgical implant into the body, or other applications intended to support or sustain life, or for any other application in which the failure of the SCILLC product could create a situation where personal injury or death may occur. Should Buyer purchase or use SCILLC products for any such unintended or unauthorized application, Buyer shall indemnify and hold SCILLC and its officers, employees, subsidiaries, affiliates, and distributors harmless against all claims, costs, damages, and expenses, and reasonable attorney fees arising out of, directly or indirectly, any claim of personal injury or death associated with such unintended or unauthorized use, even if such claim alleges that SCILLC was negligent regarding the design or manufacture of the part. SCILLC is an Equal Opportunity/Affirmative Action Employer. This literature is subject to all applicable copyright laws and is not for resale in any manner.

**PUBLICATION ORDERING INFORMATION**

**LITERATURE FULFILLMENT:**

Literature Distribution Center for ON Semiconductor  
**Phone:** 480-829-7710 or 800-344-3860 Toll Free N.A.  
**Fax:** 480-829-7709 or 800-344-3867 Toll Free N.A.  
**Email:** [orderlit@onsemi.com](mailto:orderlit@onsemi.com)

**N. American Technical Support:** 800-282-9855 Toll Free  
USA/Canada

**JAPAN:** ON Semiconductor, Japan Customer Focus Center  
2-9-1 Kamimeguro, Meguro-ku, Tokyo, Japan 153-0051  
**Phone:** 81-3-5773-3850

**ON Semiconductor Website:** <http://onsemi.com>

**Order Literature:** <http://www.onsemi.com/litorder>

For additional information, please contact your local Sales Representative